



# Instructions

# RSG III

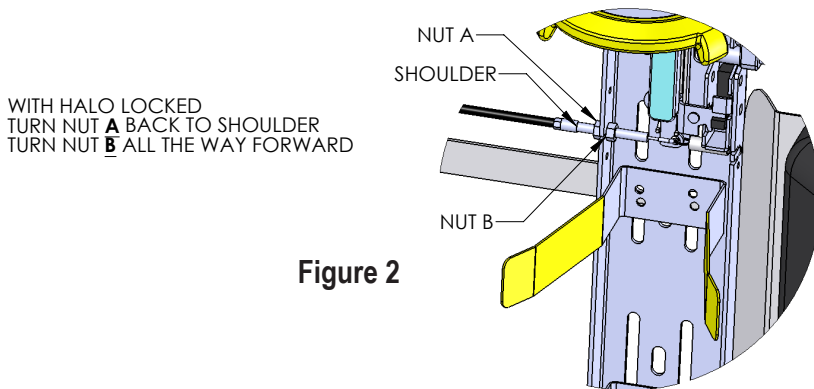


**Figure 1**

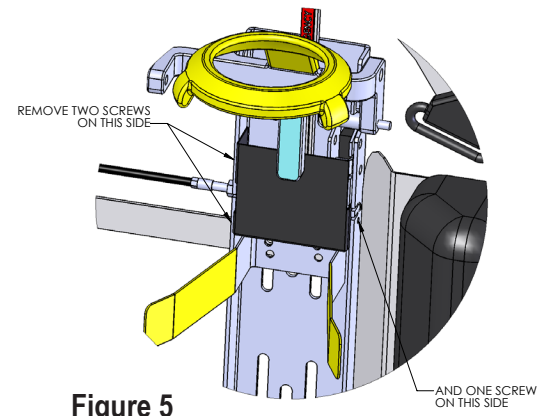
1. First, the position of the foot plate must be located, as in (Figure 1). Place the tank spring bracket on back plate, with the halo in the closed position, place a cylinder into halo and allow it to rest on tank centering spring bracket, with the tank "tight" or pushed fully in to the halo, adjust the foot plate to fit the tank height or length as shown in (Figure 1).

2. The release housing needs to be fitted to the release mounting plate, once you have decided where you are going to mount the release, Note: once installed in seat you must secure the release cable to avoid it becoming tangled in the seat belts and other loose gear, we suggest you use nylon wire tie downs to do this, 2-3 per seat should be plenty in most cases. Also avoid any sharp bends when installing/securing the release cable, sharp bends can damage cable housing. Now you can install the unit in the seat.

3. Once you have installed the unit in the SCBA seat, you may have to adjust the cable housing slightly to have a proper release of the halo, you can adjust this by simply loosening one of the two nuts on the cable assemble where it attached to the back frame, you can now adjust the release as needed, once you have the proper release, re-tighten nuts firmly (Figure 2, 3 & 4) Unit is ready to use.

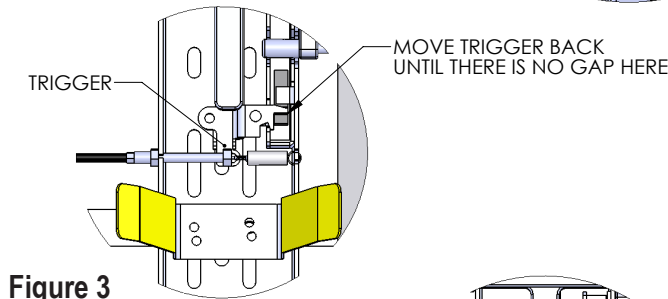


**Figure 2**

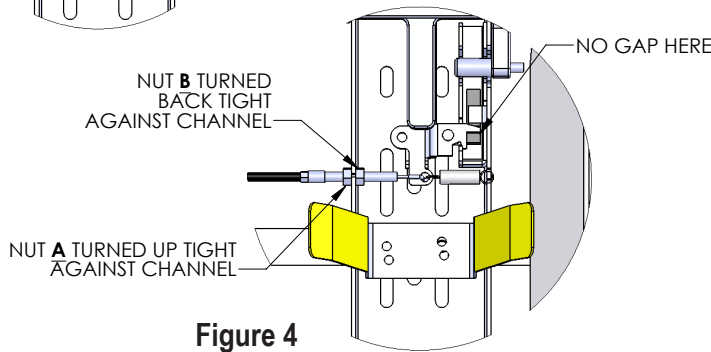


**Figure 5**

IT MAY HELP TO UNLOCK THE HALO WHILE REMOVING THE COVER



**Figure 3**



**Figure 4**

CHECK LATCH FOR PROPER ACTION, THEN REPLACE COVER

